

Bunkerproben-Entnahmeflansch-Maßblatt

DRIP-TEC Flange Dimensions

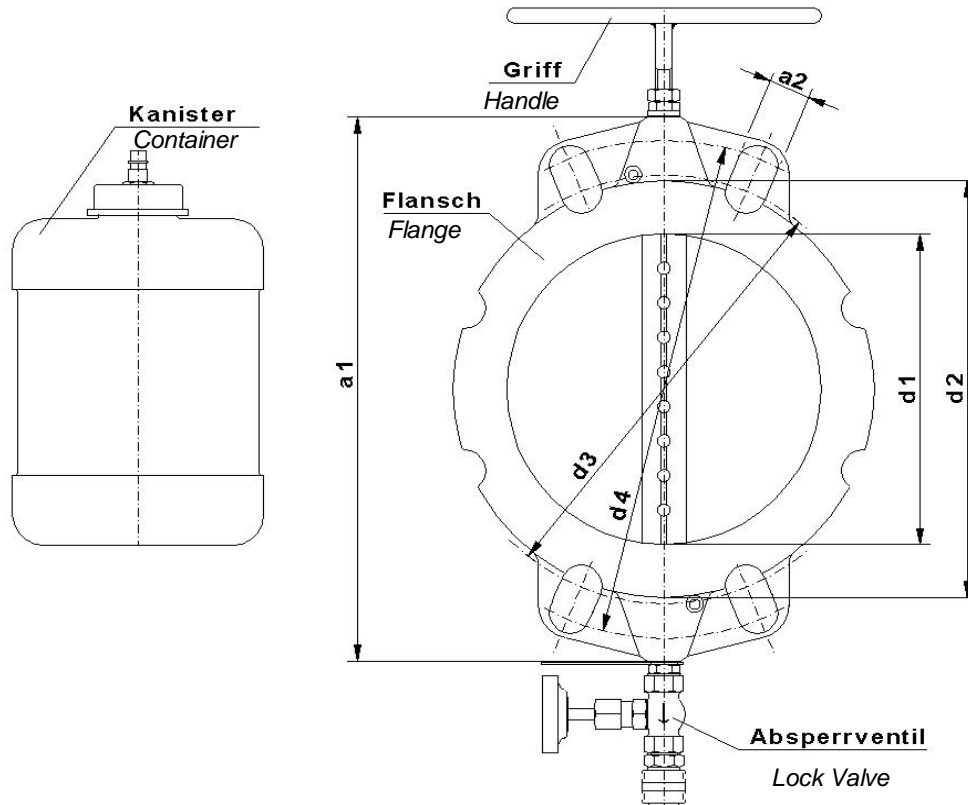

Lagerware Stock Level

DN	a1	a2	d1	d2	d3	d4	Anzahl Schrauben	Artikel-Nr
80	215	26	80	128	145	180	8	1.696
100	237	26	100	158	165	207	8	1.568
125	256	26	125	174	180	220	8	1.372
140	255	26	140	174	200	210	8	1.345
150	290	26	150	216	225	245	8	1.096
170	300	26	170	209	235	245	8	1.567
200	350	26	200	268	274	311	8 + 12	1.329
220	350	26	220	268	280	311	8	1.330
250	410	27	250	320	345	362	12	1.331
300	490	27	300	365	385	431	12	1.637
400	605	32	410	510	510	548	16	1.915

Auf Wunsch können auch andere Sondergrößen gefertigt werden

On request also other sizes can be manufactured